



Professional Radio GM Series

Radio Installation Manual

68P64112B30

Issue: July 2000

Computer Software Copyrights

The Motorola products described in this manual may include copyrighted Motorola computer programs stored in semiconductor memories or other media. Laws in the United States and other countries preserve for Motorola certain exclusive rights for copyrighted computer programs, including the exclusive right to copy or reproduce in any form, the copyrighted computer program. Accordingly, any copyrighted Motorola computer programs contained in the Motorola products described in this manual may not be copied or reproduced in any manner without the express written permission of Motorola. Furthermore, the purchase of Motorola products shall not be deemed to grant, either directly or by implication, estoppel or otherwise, any license under the copyrights, patents or patent applications of Motorola, except for the normal non-exclusive royalty-free license to use that arises by operation of law in the sale of a product.

SAFETY INFORMATION

Read this information before using your radio.

SAFE AND EFFICIENT OPERATION OF MOTOROLA TWO-WAY RADIOS

This document provides information and instructions for the safe and efficient operation of Motorola Portable and Mobile Two-Way Radios. The information provided in this document supersedes the general safety information contained in user guides published prior to 1 January 1998.

For information regarding radio use in hazardous areas, please refer to the Factory Mutual (FM) approval manual supplement.

EXPOSURE TO RADIO FREQUENCY ENERGY

Your Motorola Two-Way Radio, which generates and radiates radio frequency (RF) electromagnetic energy (EME), is designed to comply with the following National and International Standards and Guidelines regarding exposure of human beings to radio frequency electromagnetic energy:

- Federal Communications Commission Report and Order No. FCC 96-326 (August 1996)
- American National Standards Institute (C95.1 - 1992)
- National Council on Radiation Protection and Measurements (NCRP-1986)
- International Commission on Non-Ionizing Radiation Protection (ICNRP- 1986)
- European Committee for Electrotechnical Standardization (CENELEC):

ENV 50166-1 1995 E Human exposure to electromagnetic fields Low frequency (0 Hz to 10 kHz)

ENV 50166-2 1995 E Human exposure to electromagnetic fields High frequency (10 kHz to 300 GHz)

Proceedings of SC211/B 1996 "Safety Considerations for Human Exposure to EMFs from Mobile Telecommunication Equipment (MTE) in the Frequency Range 30MHz - 6 GHz." (EMF - Electro-Magnetic Fields)

To assure optimal radio performance and to ensure that your exposure to radio frequency electromagnetic energy is within the guidelines in the above standards, always adhere to the following procedures:

MOBILE RADIO OPERATION AND EME EXPOSURE

To assure optimal radio performance and that human exposure to radio frequency electromagnetic energy is within the guidelines referenced in this document, transmit *only* when people inside and outside the vehicle are at least the minimum distance away from a properly installed, externally-mounted antenna.

The table below lists the minimum distance for several different ranges of rated radio power.

Table 1 Rated Power and Distance

Rated Power of Vehicle-Installed Mobile Two-Way Radio	Minimum Distance from Transmitting Antenna
7 to 15 Watts	30.5 Centimetres (1 Foot)
16 to 50 Watts	61 Centimetres (2 Feet)
More than 50 Watts	91.5 Centimetres (3 Feet)

Mobile Antenna Installation

Install the vehicle antenna *external* to the vehicle and in accordance with:

- a. The requirements of the antenna manufacturer/supplier
- b. Instructions in the radio installation manual.

Control Station Operation

When radio equipment is used to operate as a control station, it is important that the antenna be installed outside the building and away from places where people may be in close proximity.

NOTE Refer to Table 1 for rated power and minimum distance values for transmitting antennas.

INSTALLATION WARNINGS



WARNING: Disruption of the anti-skid/anti-lock braking system by the radio transmitter may result in unexpected vehicle motion.

For vehicles with electronic anti-lock/anti-skid brakes, Motorola recommends the following radio installation precautions and vehicle braking system test procedures to ensure that the radio, when transmitting, does not interfere with the operation of the vehicle braking system. Refer to your vehicle service manual for details of your vehicle's braking system, or contact your dealer directly.

Installation Precautions:

1. Always provide as much distance as possible between the braking modulator unit and the radio, the radio antenna, and associated transmission line. Before installing the radio, determine the location of the braking modulator unit in the vehicle. Depending on the make and model of the vehicle, the braking modulator unit may be located in the trunk, under the dashboard, in the engine compartment, or in some other cargo area. If you cannot determine the location of the braking modulator unit, refer to the vehicle service manual or contact a dealer for the particular make of the vehicle.
2. If the braking modular unit is located on the left side of the vehicle, install the radio on the right side of the vehicle, and conversely.
3. Route all radio wiring, including the antenna transmission line, as far away as possible from the braking modular unit and associated braking system wiring.
4. Never activate the radio transmitter while the vehicle is in motion and the vehicle trunk lid is open.

Braking System Tests:

Be sure the following vehicle testing is done in an isolated area. The following procedure checks for the most common types of interference that may be caused by a radio transmitter to vehicle braking system:

1. Run the vehicle engine at idle speed and set the vehicle transmission selector to PARK. Release the brake pedal completely and key the radio transmitter. While NOT speaking into the microphone, verify that there are no unusual effects (visual or audible) to the vehicle lights, or other electrical equipment and accessories.
2. Repeat Step 1, except do so while speaking into the microphone.
3. Press the vehicle brake pedal slightly; just enough to illuminate the vehicle brake light(s). Then repeat Steps 1 and 2.
4. Press the vehicle brake pedal firmly and repeat Steps 1 and 2.

5. Ensure that there is a minimum of two vehicle lengths between the front of the vehicle and any object in the vehicle's forward path. Then, set the vehicle transmission selector to DRIVE. Press the brake pedal just far enough to stop the vehicle motion completely. Key the radio transmitter. Verify that the vehicle does not start to move while NOT speaking into the microphone.
6. Repeat Step 5, except do so while speaking into the microphone.
7. Release the brake pedal completely and accelerate the vehicle to a speed between 25 and 40 kilometres (15 and 25 miles) per hour. Ensure that a minimum of two vehicle lengths is maintained between the front of the vehicle and any object in the vehicle's forward path. Have another person key the radio transmitter, and verify that the vehicle can be braked normally to a moderate stop while NOT speaking into the microphone.
8. Repeat Step 7, except do so while speaking into the microphone.
9. Release the brake pedal completely and accelerate the vehicle to a speed of 30 kilometres (20 miles) per hour. Ensure that a minimum of two vehicle lengths is maintained between the front of the vehicle and any object in the vehicle's forward path. Have another person key the radio transmitter, and verify that the vehicle can be braked properly to a sudden (panic) stop while NOT speaking into the microphone.
10. Repeat Step 9, except do so while speaking into the microphone.
11. Repeat Steps 9 and 10, except use a vehicle speed of 50 kilometres (30 miles) per hour.



WARNING: For radios installed in vehicles fuelled by liquefied petroleum gas, refer to the (U. S.) National Fire Protection Association standard, NFPA 58, for storage, handling, and/or container information

OPERATIONAL WARNINGS

Potentially explosive atmospheres



WARNING: Turn off your Two-Way radio when you are in any area with a potentially explosive atmosphere, unless it is a radio type especially qualified for use in such areas (e.g. FM or Cenelec approved). Sparks in a potentially explosive atmosphere can cause an explosion or fire resulting in bodily injury or even death.

Blasting caps and areas



WARNING: To avoid possible interference with blasting operations, turn off your radio when you are near electrical blasting caps. In a "blasting area" or in areas posted "turn off two-way radio", obey all signs and instructions.

NOTE The areas with potentially explosive atmospheres referred to above include fuelling areas such as: below decks on boats; fuel or chemical transfer or storage facilities; areas where the air contains chemicals or particles, such as grain, dust or metal powders; and any other area where you would normally be advised to turn off your vehicle engine. Areas with potentially explosive atmospheres are often but not always posted.

Table of Contents

SAFETY INFORMATION	iii
--------------------------	-----

Chapter 1 INSTALLATION

1.0 Introduction.....	1-1
1.1 General Information	1-1
1.2 Plan the Installation.....	1-1
2.0 DC Power Cable Installation.....	1-1
2.1 Planning the Power Cable Installation	1-1
2.2 Power Cable Installation Procedure.....	1-2
3.0 Trunnion Installation	1-4
3.1 Planning the Mounting Trunnion Installation	1-4
3.2 Trunnion Installation Procedure	1-4
3.3 Control Head Mounting Position	1-5
4.0 Antenna Installation	1-5
4.1 Mobile Radio Operation and EME Exposure	1-5
4.2 Selecting an Antenna Site.....	1-6
4.3 Antenna Installation Procedure.....	1-6
4.4 Completing the Installation.....	1-7
5.0 Installation Options	1-9
5.1 Radio Mounting in Dashboard.....	1-9
5.2 External Speaker Installation	1-10
5.3 Remote Control Head Installation	1-11
6.0 Accessory Connections	1-13
6.1 Accessory Connector Pin Functions	1-13

Chapter 2 REDUCING NOISE INTERFERENCE

1.0 Introduction.....	2-1
1.1 Noise Sources.....	2-1
1.2 Radiated Noise.....	2-1
1.3 Conducted Noise.....	2-2
1.4 Induced Noise	2-3
2.0 Operation of a Conventional Ignition System	2-3
2.1 Introduction	2-3
2.2 Sources of Ignition Interference	2-3
3.0 Detection of Noise Sources	2-5
3.1 Noise Detection Procedure	2-5
3.2 Sources of Noise.....	2-7
4.0 Noise Reduction Techniques.....	2-7
4.1 General	2-7
4.2 Ignition System Interference	2-8
4.3 Alternator/Generator Whine	2-9

4.4	Voltage Regulator Noise	2-11
4.5	Hood and Trunk Lid Noise	2-11
4.6	Other Electrical Noises	2-12
4.7	Wheel Static.....	2-12
4.8	Ground Bonding.....	2-12

Chapter 1

INSTALLATION

1.0 Introduction

1.1 General Information

There are two methods of installing your mobile radio:

1. Using the direct mounting trunnion and power cables supplied with a standard radio package.
2. Mounted in the car radio cut-out (using the required GLN7320_ mounting kit, per ISO7736).

An accessory connector on the rear of the radio (see Figure 1-4 Connections to the Back of Radio) enables you to attach different accessories required for the installation.

A ten-pin telephone type connector on the front control head panel (see Figure 1-5 Transmission Hump Mounting (Top) and Below Dash Mounting (Bottom)) provides for the connection of various types of microphones.

1.2 Plan the Installation

1. Mount the radio horizontally near the driver, so the driver can easily view, access and operate the controls and accessories.
2. Ensure that the location is not exposed to dirt and moisture.
3. Verify that there will be sufficient space around the mobile unit for air flow and installation.
4. Check that there is enough routing space for the power cable connector and the antenna coaxial cable.
5. Plan the best place to run connections to minimize pinching, crushing, and overheating of wires and cables.

NOTE In a vehicle with an airbag, make sure that the mounting location of the mobile radio, or of any radio accessory, is not in the deployment path of the air bag.

2.0 DC Power Cable Installation

2.1 Planning the Power Cable Installation



CAUTION: This radio must be operated only in negative ground electrical systems. Operating the radio on a positive ground system will cause the cable fuse to short-circuit. Check the vehicle ground polarity before you begin the installation.

The 3 metres (10 feet) DC power cable shipped with the radio should be long enough to be installed in most vehicles. Take the following precautions before you begin:

- Whenever possible, avoid routing the cable above the catalytic converter.
- Use grommets whenever a cable has to pass through a hole in a metal panel.

The following table lists power cables available for this radio:

Table 1-1 Power Cables

Number	Description	Rating
HKN4137_	Low power cable to battery	1-25W; 15A fuse; 14 AWG 3m
HKN4191_	High Power Cable to battery	25-45W; 20A fuse; 12 AWG 3m

2.2 Power Cable Installation Procedure

Begin the power cable installation as follows:

1. Determine a routing plan, keeping in mind where the radio is to be mounted.



CAUTION: Improper handling with the power cable may cause shorting to ground. Ensure that during radio installation the power cable fuse is removed.

2. Locate an existing hole with grommet in the vehicle fire wall, or use a 9.5 mm (3/8-inch) bit to drill an access hole in the fire wall. Install a grommet with a 5 mm (3/16-inch) inside diameter into the hole to protect the power cable.



CAUTION: Be very careful not to damage existing wires.

3. From inside the vehicle, feed the red and black leads (without the lugs attached) through the access hole and into the engine compartment. (See Figure 1-1 Power Cable Routing into the Engine Compartment)

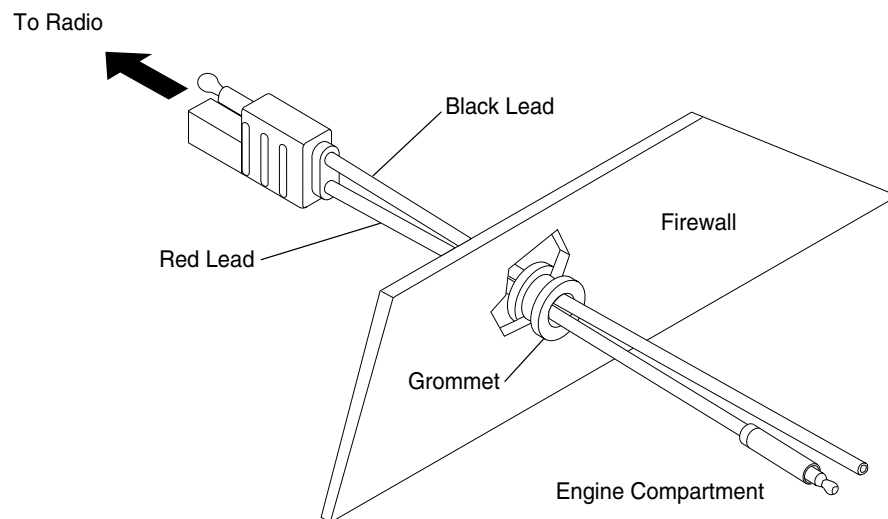

FL0830246-O

Figure 1-1 Power Cable Routing into the Engine Compartment

4. Connect the black lead of the power cable to the nearest vehicle chassis ground point (using the provided ring lug if necessary). Shorten the black lead to remove any excess cable. (See Figure 1-2 Power Cable Assembly.)

NOTE Locate a good vehicle ground point. The vehicle frame provides the best ground. Optimum radio performance can only be achieved with a very low resistance ground connection. Verify that the connections between the battery negative terminal, vehicle chassis, and engine block have low resistance.

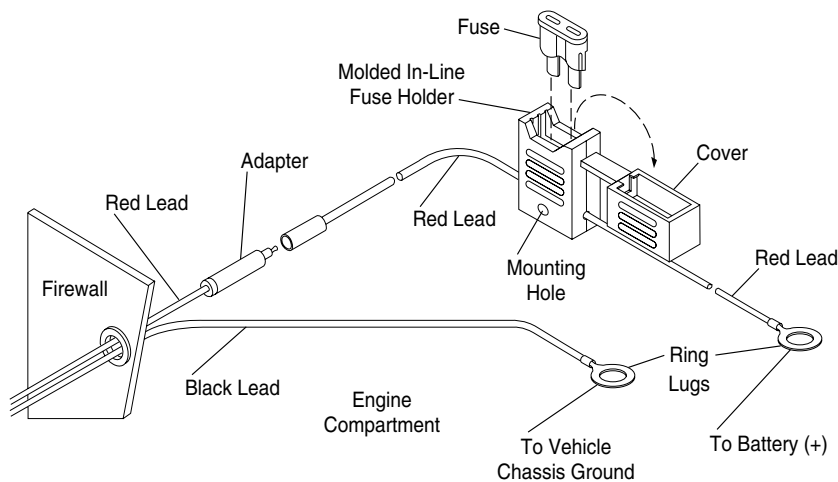

Figure 1-2 Power Cable Assembly

FL0830247-O

5. Place the fuse holder close to the battery. Ensure that it is not near any hot engine component. Mount the fuse holder using its mounting hole and dress the wires as required.
6. Insert the stripped end of the red lead of the fuse holder into the ring lug hole and crimp it. Connect the fuse holder red adapter lead plug to the mating receptacle on the red lead of the power cable. (See Figure 1-2 Power Cable Assembly.)
7. Connect the power cable black lead directly to the vehicle chassis ground.
8. Connect the red lead ring lug from the fuse holder to the positive (+) battery terminal. Make sure the adapter cable is connected to the main power cable red lead.

NOTE Failure to mount the red lead of the power cable kit directly to the battery may result in severe alternator whine interference.

Carefully check that all connections are proper. Insert the fuse into the fuse holder and close the cover. (See Figure 1-2 Power Cable Assembly).

3.0 Trunnion Installation

3.1 Planning the Mounting Trunnion Installation

The standard mounting trunnion allows the radio to be mounted to a variety of surfaces.

1. Ensure the surface can support the weight of the radio.
2. Although the trunnion can be mounted to a plastic dashboard, it is recommended that the mounting screws be located so they penetrate the supporting metal frame of the dashboard.

3.2 Trunnion Installation Procedure

1. Select either the transmission hump or an open underneath portion of the dash to mount your radio. (See Figure 1-5 Transmission Hump Mounting (Top) and Below Dash Mounting (Bottom)). When mounting the trunnion on the transmission hump, be careful that the transmission housing is not affected.
2. Use the trunnion mounting bracket as a template to mark the hole positions on the mounting surface. Use the innermost three holes for a curved mounting surface, such as the transmission hump, and the three outermost holes for a flat surface such as under the dash.
3. Center-punch the spots you marked and use a 4 mm (5/32-inch) bit to drill a hole at each location.
4. Secure the trunnion mounting bracket to the mounting surface with the three self-tapping screws provided. (See Figure 1-5 Transmission Hump Mounting (Top) and Below Dash Mounting (Bottom)).
5. Slide the radio into the trunnion. Secure the radio with the two thumb screws provided. (See Figure 1-3 Radio into Trunnion.)

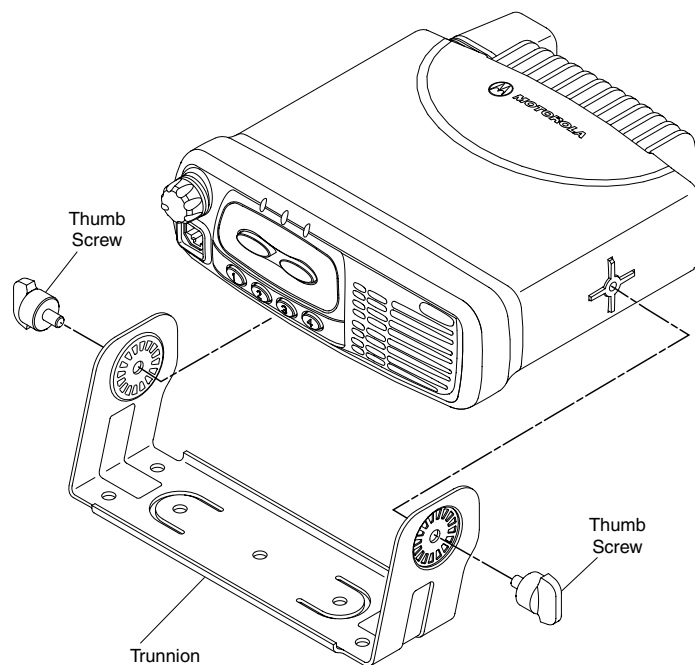

Figure 1-3 Radio into Trunnion

3.3 Control Head Mounting Position

The control head is designed to be removed from the housing and turned to any position within a 180° radius. This provides multiple mounting options for the radio. For example, the radio may be mounted on either side of the vehicle transmission tunnel to facilitate the safest and most ergonomically ideal position. The control head may then be turned to provide the most convenient access.

To reposition the control head:

1. Insert a small flat blade screwdriver, or similar instrument, in the recess between the control head and the radio housing.
2. Press until the control head releases. Repeat the process on the opposite side of the radio.
3. Pull the control head away while ensuring that the flex connector remains attached.
4. Rotate the control head, and fold the flex circuit to align it to the new position.
5. Push the control head into the housing until the protruding tabs snap into place.



CAUTION: The contact surface of the flex circuit should be facing the printed circuit board.

4.0 Antenna Installation

4.1 Mobile Radio Operation and EME Exposure

Observe the following caution and electromagnetic energy exposure (EME) statements when installing antennas:



CAUTION: Use caution when installing antennas with mobile radio equipment using transmitter power in excess of 7 Watts.

NOTE For low-power mobile radios (7 Watts, or less), there are no antenna type or installation restrictions.

To assure optimal radio performance and that human exposure to radio frequency electromagnetic energy is within the guidelines referenced in this document, transmit *only* when people inside and outside the vehicle are at least the minimum distance away from a properly installed, externally-mounted antenna.

The table below lists the minimum distance for several different ranges of rated radio power.

Table 1-2 Rated Power and Distance

Rated Power of Vehicle-Installed Mobile Two-Way Radio	Minimum Distance from Transmitting Antenna
7 to 15 Watts	30.5 Centimetres (1 Foot)
16 to 50 Watts	61 Centimetres (2 Feet)
More than 50 Watts	91.5 Centimetres (3 Feet)

4.2 Selecting an Antenna Site

1. Install the vehicle antenna *external* to the vehicle and in accordance with:
 - a. The requirements of the antenna manufacturer/supplier
 - b. Instructions in the radio installation manual.
2. The best mounting location for the antenna is in the center of a large, flat conductive surface. In almost all vehicles, mounting the antenna in the center of the roof will satisfy these requirements. A good alternate location is in the center of the trunk lid. If you use the trunk lid, ensure that the trunk lid is grounded by connecting grounding straps between the trunk lid and the vehicle chassis.
3. Ensure the antenna cable can be easily routed to the radio. Ensure that the antenna cable is routed separately and not in parallel to any other vehicle wiring or mobile radio cable wiring.
4. Check the antenna location for any electrical interference.

NOTE Any two metal pieces rubbing against each other (such as seat springs, shift levers, trunk and hood lids, exhaust pipes, etc.) in close proximity to the antenna can cause severe receiver interference.

5. If the vehicle is equipped with an electronic anti-lock braking system (ABS) and the antenna will be trunk mounted, then install the antenna on the side opposite to the braking modulator box. This minimizes radio interference to the modulator box from the radio.
6. Motorola offers a glass-mount antenna as an accessory. It is usually mounted on the rear window. This antenna should be placed as high as possible on the vehicle. Ensure that a rear-window defogger element does not touch the inductive “button” on the mounting foot of the antenna.
7. Make sure the mobile radio antenna is installed at least 30.48 cm (1 foot) away from any other antenna on the vehicle.

4.3 Antenna Installation Procedure

1. Mount the antenna according to the instructions provided with the antenna kit. Run the coaxial cable to the radio mounting location. If necessary, cut off the excess cable and install the cable connector.
2. Connect the antenna cable connector to the radio antenna connector on the rear of the radio. (See Figure 1-4 Connections to the Back of Radio.)

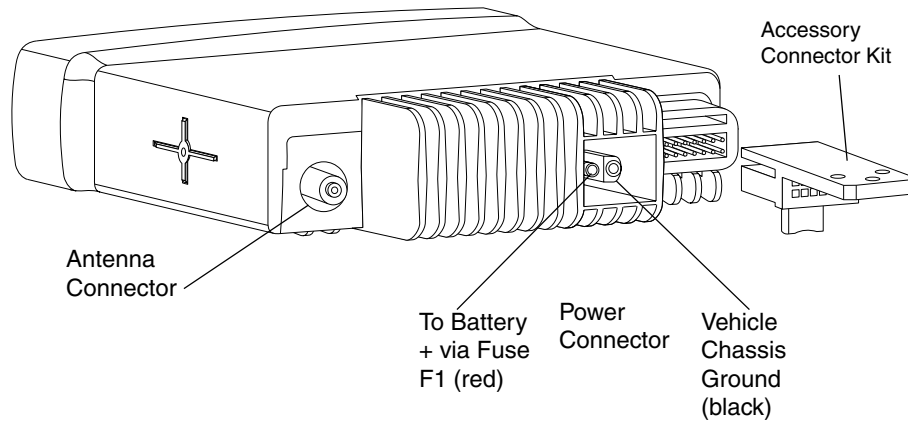
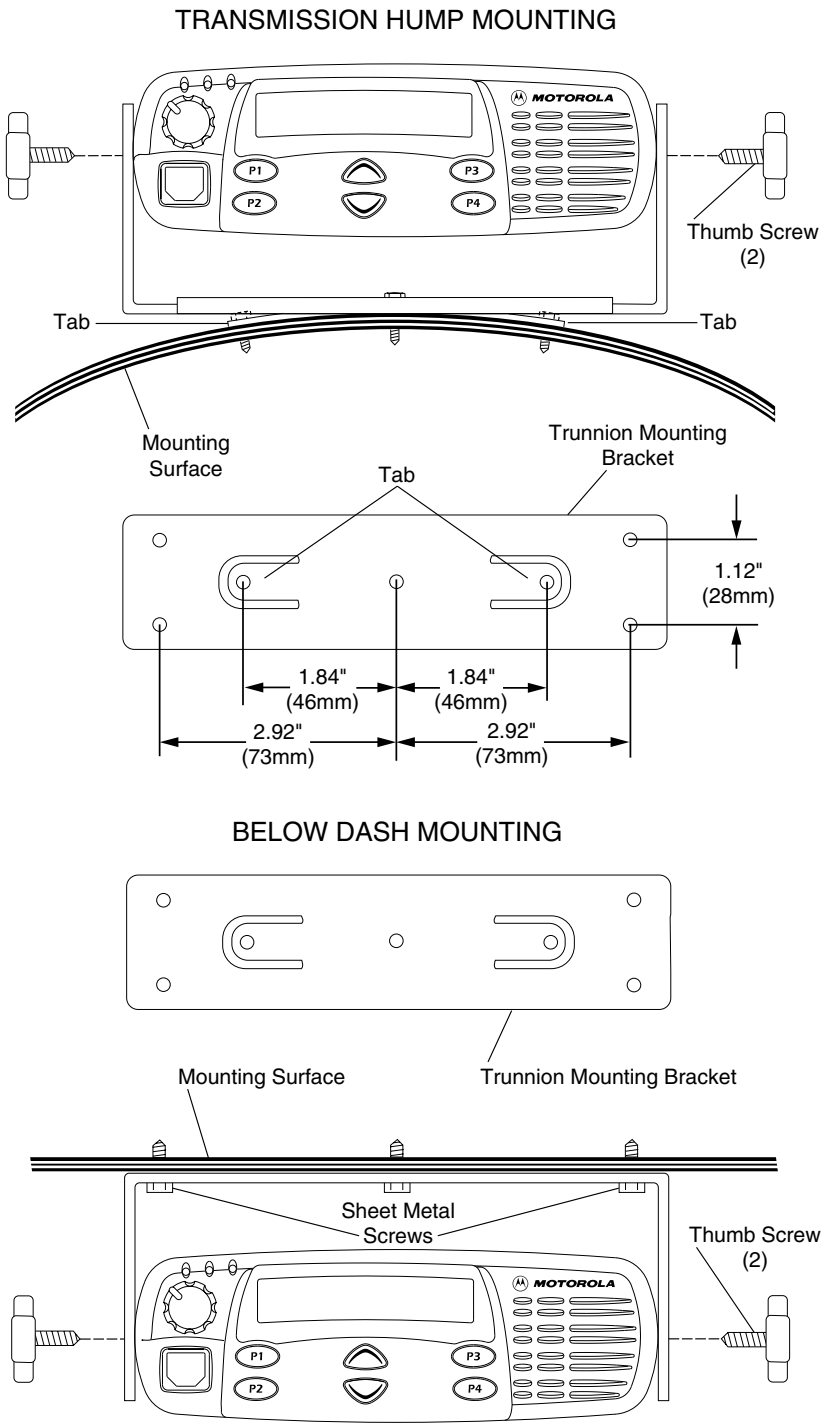

Figure 1-4 Connections to the Back of Radio

FL0830249-O

4.4 Completing the Installation

1. Mount the microphone clip to a convenient spot near your radio.
2. Your microphone has a telephone-type connector at the end of its cord. Plug the microphone into the control head connector.
3. To complete your radio installation, plug the power cable into the radio power connector. (See Figure 1-4 Connections to the Back of Radio.)



FL0830250-O

Figure 1-5 Transmission Hump Mounting (Top) and Below Dash Mounting (Bottom)

5.0 Installation Options

5.1 Radio Mounting in Dashboard

5.1.1 To Install the Radio in an Automotive Dashboard:

1. Open out the radio cut-out in the dashboard to ISO 7736 specification (182mm x 53mm).
2. Remove the Top plastic cover off the radio.
3. Insert the mounting frame into the cut-out and retain it by bending back the relevant fixing tabs, using all 6 where possible, to hold it in place. Press the bezel onto the mounting frame.

- NOTE**
1. The tabs are easily bent back by twisting a large flat-bladed screwdriver in the slot behind the tabs.
 2. For a more secure installation the top and rear of the frame should also be secured with screws.
 3. The demounting tool can be used as an aid to mounting as well as demounting.

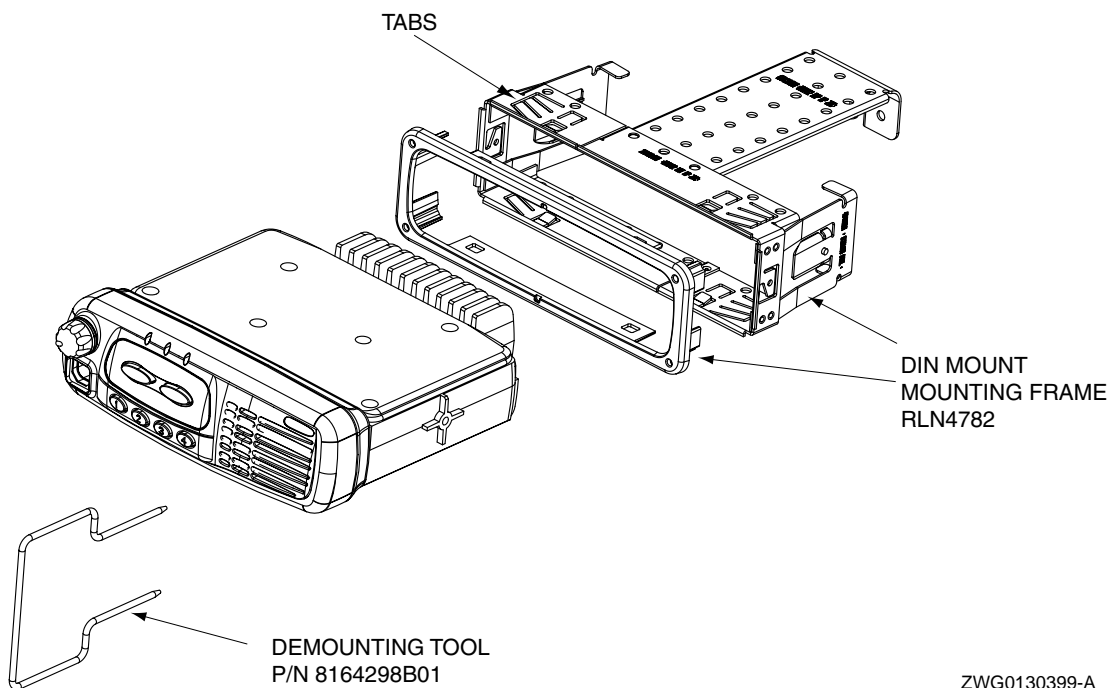

ZWG0130399-A

Figure 1-6 Mounting the Radio into the Dashboard

5.1.2 To Mount the Complete Radio in the Frame:

1. Provide the electrical connections to the radio for power, antenna and accessories as shown in Figure 1-4 Connections to the Back of Radio.
2. Plug in all the connectors and push the radio firmly into the mounting frame until the two springs snap into place.

5.1.3 To Remove the Radio / Remote Mount from the Frame

1. Push the two demounting tools (see Figure 1-6 Mounting the Radio into the Dashboard) through the openings in the frame until the two springs release the radio.
2. Slide out the radio.

NOTE

1. The fixing tabs should be checked for tightness each time the radio is removed. The tabs are easily tightened by twisting a large flat-bladed screwdriver in the slot behind the tabs.
2. The frame is not designed for daily mounting and demounting.

5.2 External Speaker Installation

1. Remove the speaker from the trunnion bracket by loosening the two wing screws.
2. Choose a place to mount the speaker.
3. Use the trunnion bracket as a template to mark the locations of the three mounting holes.
4. Centerpunch and drill a 4 mm (5/32-inch) diameter hole at each location.
5. Mount the trunnion bracket with the screws supplied. (See Figure 1-7 Mounting the Speaker Under the Dashboard.)
6. Insert the speaker into the trunnion bracket and tighten the two wing screws.
7. Insert the external speaker accessory plug into the accessory connector of the radio.

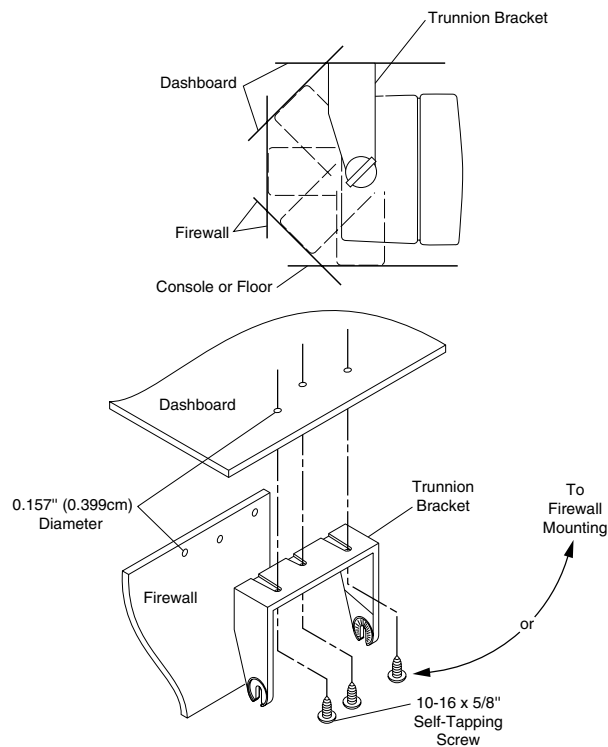

FL0830253-O

Figure 1-7 Mounting the Speaker Under the Dashboard

5.3 Remote Control Head Installation

5.3.1 Removing the Front Housing

1. Remove the Controlhead from the Transceiver by inserting the dismantling tool (Motorola part number 6686119B01) in the recess between the Controlhead and the Transceiver.
2. Split the Controlhead into Front and Back housings by inserting the dismantling tool in the recess between them.

NOTE 1. To minimise cosmetic damage disassemble from the bottom side, (label side).
2. The Controlhead Back Housing is not required for remote mounting.

3. Remove the flex from the Transceiver only.

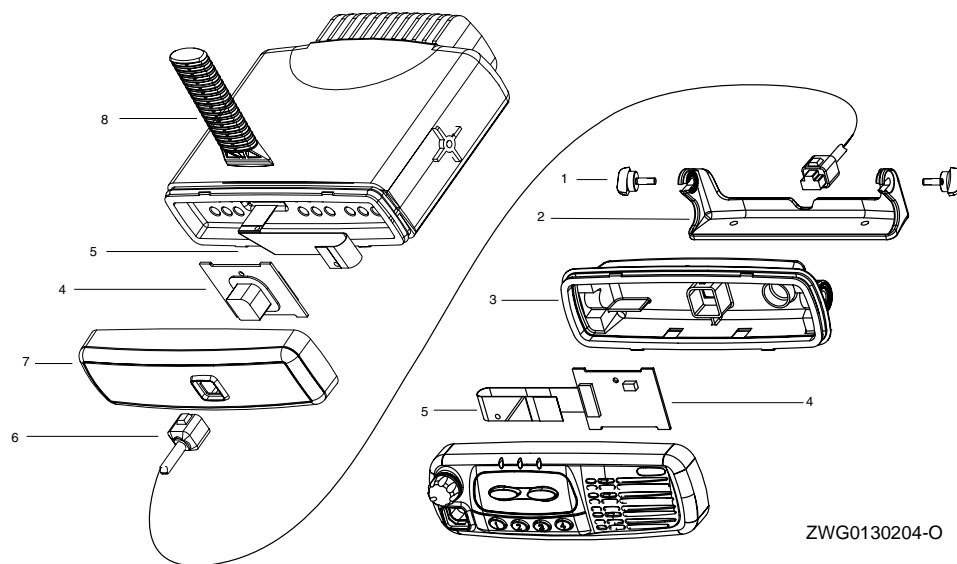

Figure 1-8 Remote Front and Back Housings

5.3.2 To Assemble the Remote Back Housing

1. Remove the twists from the flex and connect the flex from the Controlhead to the Remote Back PCB connector.

NOTE For correct orientation of the flex, align the 'O' on the flex with the 'O' on the PCB.

2. Align the speaker with the speaker support.
3. Press the Controlhead onto the Remote Back Housing until **ALL** the tabs snap into place.

5.3.3 To Assemble the Remote Front Housing:

1. Connect the flex from the Remote Front Housing to the top small connector in the Transceiver.

NOTE For correct orientation of the flex in the Transceiver, the "plastic" tab should be up, contacts facing down. Align the 'O' on the flex with the 'O' on the Transceiver. The flex must be pushed into the connector until it meets the stop.

2. Press the Remote Front Housing onto the Transceiver chassis until the chassis tabs snap into place.

5.3.4 To Install the Remote Controlhead:

1. Position the Remote Mount Bracket (Item2 in Figure 1-8 Remote Front and Back Housings) in the desired location and mark the positions of the mounting holes.
2. Centrepunch the marked spots and drill 4mm holes at each spot.
3. Fix the Remote Mount Bracket in position using the supplied screws.
4. Route the Remote Cable (Table 1-3) as required, feeding it through the bracket (a 20mm hole is required for the cable plug).
5. Push the cable plug into the Remote Front and Back Housing until it snaps into place.
6. Snap the assembly into the bracket.
7. Adjust the assembly as required then fix it in position with the wing screws supplied.

Table 1-3 Associated Components

Item	Description	Part Number
1	Wingscrews	0305760W02
2	Remote Bracket	0764275B01
3	Remote Back Housing (GM380/GM1280)	1564268B01
	Remote Back Housing (GM340/GM360/GM640/GM660)	1564269B01
4	Remote PCB (2 off per kit)	GLN7362
5	Flex (2 off per kit)	8486127B01
6	Cable Kit 3M	RKN4077*
	Cable Kit 5M	RKN4078*
	Cable Kit 7M	RKN4079*
7	Remote (Transceiver) Front Housing	1564270B01
8	Dismantling Tool	6686119B01

* Cable Kits to be ordered separately.

NOTE Specifications are subject to change without notice.
Contact your Motorola dealer for the latest specifications.

6.0 Accessory Connections

6.1 Accessory Connector Pin Functions

This section gives a description of the accessory connector pin functions.



CAUTION: The accessory connections shown are not compatible to some other models of Motorola radios. Check the appropriate accessory or technical manual for further information.

Table 1-4 Connector Pin Functions

Pin	Function	Description
1	External Speaker -	Speaker - and Speaker + (Pin 16) are used to connect an external speaker. The audio PA is a bridge amplifier with a minimum load resistance of 3.2 Ω . The internal speaker can be disabled by removing the control head. Disconnect the internal speaker and assemble the control head back to the radio.
2	External Mic Audio	External or Emergency Mic depends on dealer programming. This microphone signal is independent of the microphone signal on the microphone connector. The nominal input level is 80mV for 60% deviation. The DC impedance is 660 Ω and the AC impedance is 560 Ω .
3	Digital In 1	This is a digital input only and the primary use for this pin is external PTT. This pin must be used if fast DATA PTT is required. (See Note 1).
4	Digital Out 2	This is a digital output only and the primary use for this pin is as an external alarm output (See Note 3).
5	Flat_TX_Audio (NPD Data Out)	This input is intended for injecting signals into the transmit path that should not be filtered; for example, the analog output of a modem. The nominal input level is 150mVrms for 60% deviation. The impedance is greater than 25k Ω .
6	Digital In 3	This is a digital input only. Function depends on dealer programming. (See Note 4).
7	Ground	Used as ground for both analog and digital signals
8	Digital In/Out 4	This is a digital input/output depending on dealer programming. (See Notes 1, 2).
9	Digital In 5 with Wakeup Emergency (NPD Call RQS)	This is a digital input only. Emergency can be enabled via the CPS. To activate, this line must be connected to ground; this will turn on the radio. The CPS details which functions may be assigned to this pin by the codeplug.
10	Ignition Detect	Connecting this line to the ignition line of the vehicle will automatically turn the radio on when the ignition of the vehicle is turned on.

Table 1-4 Connector Pin Functions

Pin	Function	Description
11	Receiver Audio (NPD Data In)	There are two possible outputs: (1) Discriminator Audio; and (2) Continuous filtered RX audio. The nominal output level for Discriminator Audio is 330m Vrms at 60% deviation and for Filtered Audio 600m Vrms at 60% deviation at 1kHz. Function depends on dealer programming. For NPD calls, this uses discriminator audio and cannot be configured by the CPS.
12	Digital In/Out 7 (CTS)	This digital input/output function depends on dealer programming.
13	Switched Battery Voltage	This voltage is available when the radio is switched on. The maximum current is 1A.
14	Digital In/Out 8 Hook (Clear)	This is a digital input/output depending on dealer programming. (See Notes 1, 2). This hook line is in parallel to the hook line of the control head microphone connector. This port reads "0" when the microphone is on-hook and "1" when off-hook. It is assumed that the hook is a mechanical switch, so the software will always debounce this input.
15	RSSI	This is an analog output which indicates the strength of the received signal.
16	External Speaker +	Positive output of radio's audio PA (see Pin 1).
17	Bus +	This pin is used for flashing and for programming the radio.
18	Boot Control	To enter Boot Mode this line must be connected to ground when the radio is switched on.
19	Reserved	Reserved.
20	Reserved	Reserved.

- Note 1: **Digital Input**
4.7 k Ω Internal Pull Up Resistor to +5V.
Maximum Input Voltage accepted as Low = 0.6V
Minimum Input Voltage accepted as High = 3.0V
- Note 2: **Digital Output**
4.7k Ω Internal Pull Up Resistor to +5V
Maximum Current when Output Low = 10mA
Maximum Voltage when Output Low = 0.5V @ 10mA
- Note 3: **High Current Digital Output**
4.7k Ω Internal Pull Up Resistor to continuous B+
Maximum Current when Output Low = 200mA
Maximum Voltage when Output Low = 1.7V @200mA
- Note 4: **Digital Input**
10k Ω Internal Pull Up Resistor to +5V
Maximum Input Voltage accepted as Low = 0.6V
Minimum Input Voltage accepted as High = 3V

6.2 Accessory Connection Plan



CAUTION: The accessory connections shown are not compatible to some other models of Motorola radios. Check the appropriate accessory or technical manual for further information. Ensure correct position of the accessory connector.

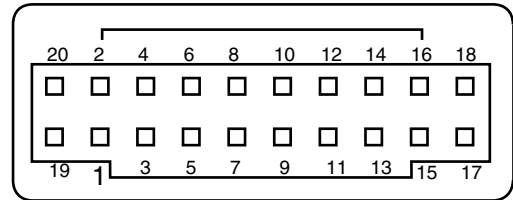
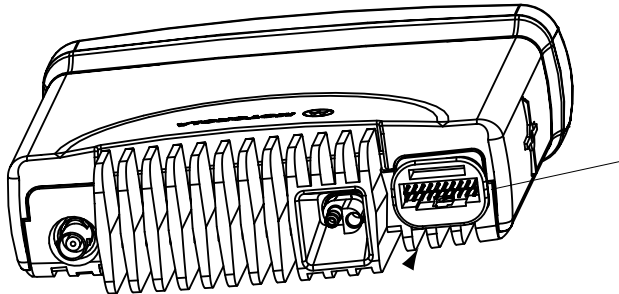

* Note the location of pin 1.

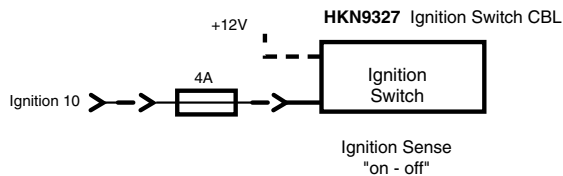
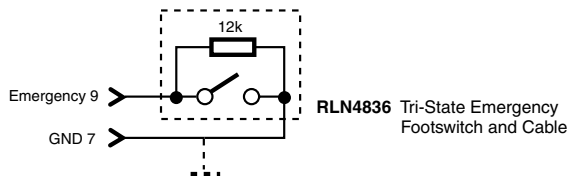
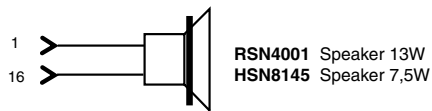

GKN6272 External Alarm, Relay and Cable

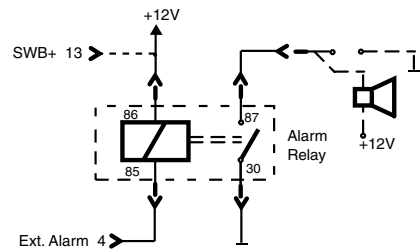
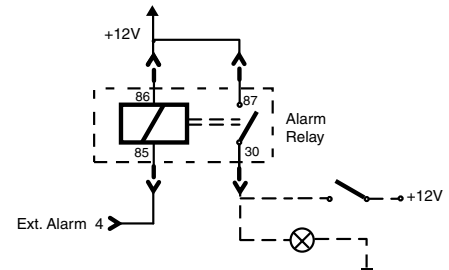

CAUTION: DO NOT short pin 16 or 1 on the accessory connector to ground; this may damage the radio.

REDUCING NOISE INTERFERENCE

1.0 Introduction

Electrical noise generated by the electrical system of a vehicle, as well as local ambient noise, can interfere with normal operation of mobile radios. Satisfactory operation of a mobile radio may require slight or heavy noise reduction, depending upon the relative strength of the radio signal, and upon the ability of the radio to reject undesired noise. These requirements vary from one vehicle to another, depending upon the vehicle type and required coverage area. When operating in a strong signal area, a certain amount of noise interference can be tolerated. In weak signal areas, however, noise reduction becomes very important. As a rule of thumb, noise levels create greatest interference in the 25-50MHz band and reduce with increasing frequency.

Before attempting any noise reduction procedures, determine the noise source(s). Then, follow a logical, systematic method of elimination until the interference is eliminated or reduced to an acceptable level.



CAUTION: Do not add interference elimination equipment to vehicles equipped with electronic ignition systems before obtaining advice from the vehicle manufacturer. Addition of some noise suppression components may interfere with proper operation of electronic ignition systems and could seriously damage them.

Care and patience must be exercised in locating and eliminating noise sources. There may be several sources of noise, each slightly stronger or weaker than the other. Elimination of one source may seem ineffective because another noise source remains active at a barely discernible difference in level. Consult a service manual for the vehicle to determine what noise reduction provisions the manufacturer applies when AM, AM/FM, or CB radios are installed as original equipment. These radios are also subject to electrical noise interference, and the manufacturer may install noise suppression components only upon those vehicles which require radio equipment at the time of manufacture. These noise suppression components should be added in any first attempt to suppress noise.

1.1 Noise Sources

The three major noise sources affecting mobile radio systems are: (1) radiated noise, (2) conducted noise, and (3) induced noise. (See Figure 2-1 Noise Sources for typical vehicular noise sources.)

1.2 Radiated Noise

Radiated noise enters the radio through the antenna along with the desired signal and can block or degrade desired communication. It can be generated by power lines, fluorescent lights, or by electrical discharges from static build-up, ignition systems, or electrical motors. Radiated noise is the most common cause of mobile radio interference.

When a spark discharge or arc takes place through air, energy is radiated at frequencies from a few kilohertz to hundreds of megahertz. This spurious radiation may have some energy radiated at a frequency near or even identical to the desired radio signal. The standard receiver may be unable to distinguish between the two signals (desired and noise). Therefore they both enter the receiver, resulting in degradation of the desired signal.

It is impractical to prevent all arcing in the standard vehicle electrical system. In an 8-cylinder engine running at 2,000 RPM, arcing occurs across the spark plugs at a rate of 8,000 sparks per minute or 133 sparks per second. Electrical motors and generators also produce arcs.

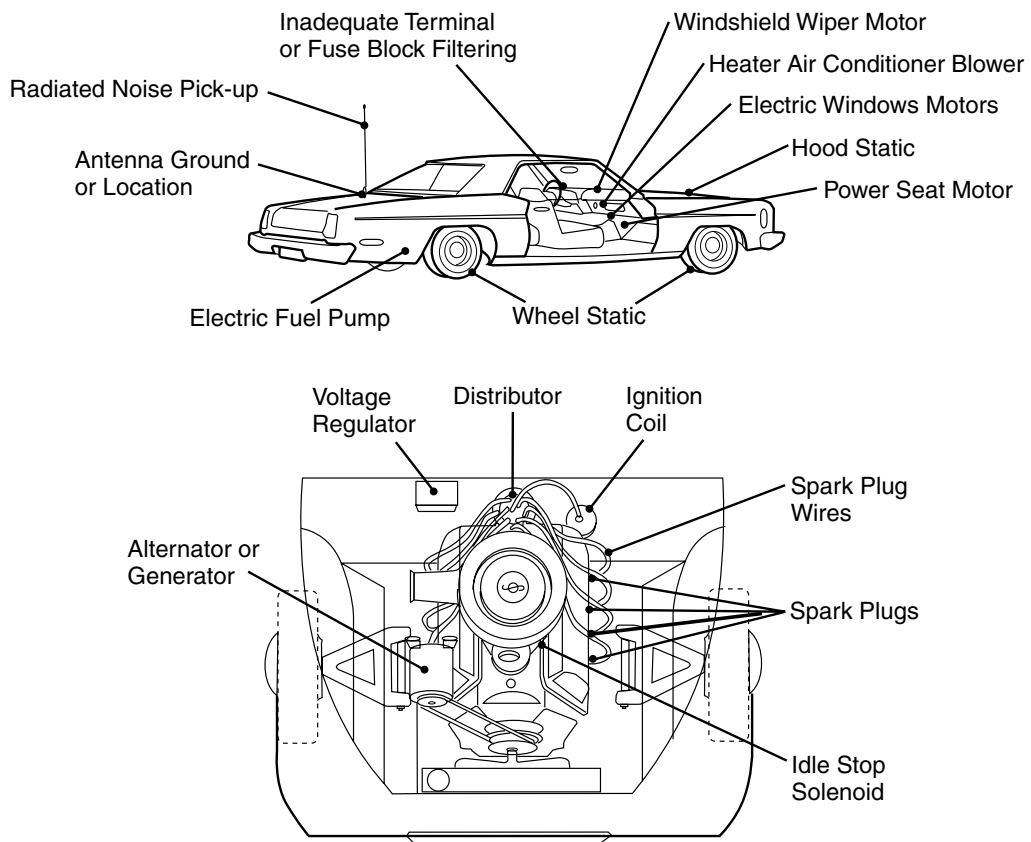

FL0830260-O

Figure 2-1 Noise Sources

1.3 Conducted Noise

Conducted noise enters the radio through the points where the radio is attached to the vehicle's electrical system such as battery cables, ignition switch, chassis ground etc. It can be generated by electrical transients, electrical motors, poor grounding points, or inadequate electrical system filtering (from alternators, generators, voltage regulators, or weak batteries). Conducted noise can degrade both transmit and receive performance of a mobile radio.

1.4 Induced Noise

Induced noise enters the radio through the proximity of radio wiring to other wiring in the vehicle. Electrical currents through the standard vehicular wiring can induce undesirable noise signals into the radio cabling. Communication is degraded simply because the wiring provides a transformer-type coupling action without any actual physical connection. Induced noise can degrade both transmit and receive performance of a mobile radio.

2.0 Operation of a Conventional Ignition System

2.1 Introduction

To effectively reduce ignition interference in a vehicle, it is well to understand the operation of an automobile ignition system.

Ignition is necessary in a gasoline engine to ignite the gasoline vapor and the air mixture in its cylinders. The system is made up of the battery, distributor, breaker points, coil, condenser, and spark plugs. The battery is the only electrical source of power in an automobile, so the lower battery voltage must be stepped up to the high voltage necessary to arc across the spark plug electrodes. This arc ignites the gas mixture.

2.2 Sources of Ignition Interference

In the conventional ignition system (Figure 2-2 Typical Vehicular Ignition System, Simplified Schematic Diagram) a mechanical circuit breaker (the cam and points in the distributor) opens the primary circuit of the ignition coil, and high voltage is developed at the secondary. This high voltage is synchronized and applied to each spark plug by the distributor.

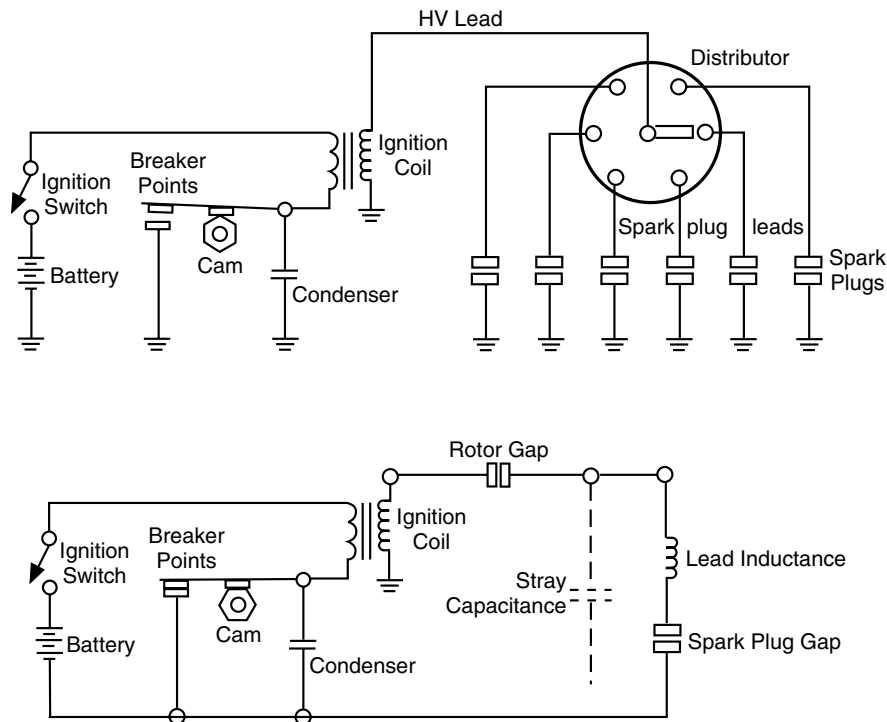

FL0830261-O

Figure 2-2 Typical Vehicular Ignition System, Simplified Schematic Diagram

The battery is connected to the primary winding of the coil through the ignition switch. The primary circuit is returned to the battery through the breaker points, which are bypassed by the condenser. The points are normally closed. As the cam shaft is rotated by the engine, its lobes or corners open and close the points in proper synchronization with the piston in each cylinder.

With the ignition switch on and the breaker points closed, coil primary current builds up at a rate determined by the coil inductance.

When the breaker points open, primary current decreases and, by self-induction, an electromotive force is induced in the primary which is many times greater than the battery voltage. The high voltage induced in the coil secondary causes a spark across the distributor rotor-to-spark plug wire gap and then across the spark plug gap for a short interval of time when the breaker points open. The condenser reduces arcing of the points.

The secondary circuit of the ignition coil, including the distributor rotor gap and the spark gap, is the main source of ignition interference. The lead inductance and stray capacitance provide a tuned circuit. Because the discharge of the circuit is through a low resistance (ionized spark gap), the circuit tends to oscillate. The frequency and amplitude of oscillation vary as current changes in the spark gap.

3.0 Detection of Noise Sources

3.1 Noise Detection Procedure

Detection of offending noise sources is the heart of noise suppression because, after the noise source is identified, the solution becomes obvious. A logical methodical procedure is basic to the effective noise suppression.

Use your available equipment to best advantage. A pick-up loop, about one inch in diameter, can be connected to a portable CB radio or a mobile radio being operated at a frequency similar to the installed radio frequency but from an isolated supply voltage. The pick-up loop can be moved throughout the vehicle with the radio used as a radiated noise detector. Be sure the pick-up loop has sufficient insulation to prevent the input of the radio from coming into direct contact with high voltage points in the vehicle ignition system.

A non-polarized bypass capacitor, which has alligator clips firmly attached, can be used on a trial-and-error basis to locate wiring which needs additional filtering. Keep capacitor lead lengths short for best suppression. Ceramic disc capacitors are not as suitable or effective as automotive coaxial capacitors. (See Figure 2-3 TLN8845_ Noise Reduction Kit for Alternator-Equipped Vehicles and Figure 2-4 TLN6252_ Noise Reduction Kit for Generator-Equipped Vehicles for part numbers.)

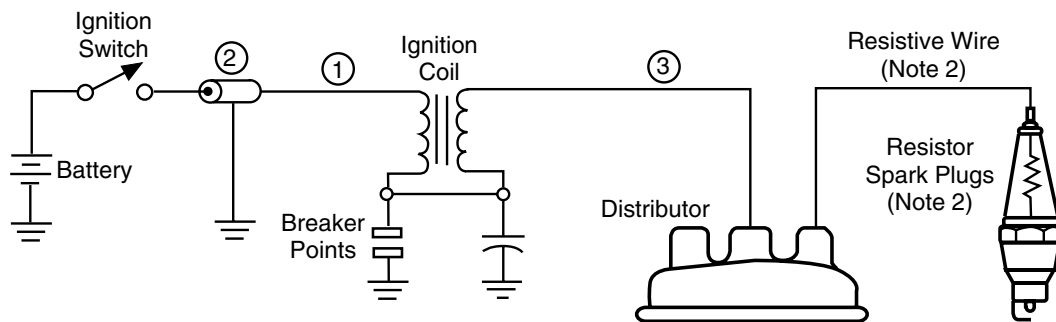

Notes:

- 1. Noise reduction can only be achieved if components are grounded properly.
- 2. Items not supplied in kit. See auto parts dealer.

FL0830262-O

Reference Number	Quantity	Motorola Part Number	Description
1	1	0100839913	Lead & Lug Assembly
2	1	0882571B02	Capacitor, Coaxial (0.1µF, 100V)
3	1	3000502396	Ignition Coil Suppressor Cable
-	1	0180782A52	Hood Wipers (2) and Mounting Hardware Kit (not illustrated).

Figure 2-3 TLN8845_ Noise Reduction Kit for Alternator-Equipped Vehicles

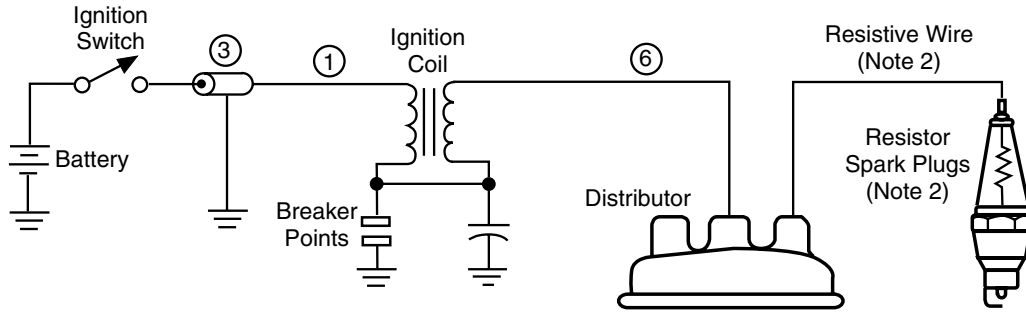

Notes:

1. Noise reduction can only be achieved if components are grounded properly. Be sure that all the capacitors and the generator field suppressor assembly are grounded properly. This may require bonding straps for proper bypass capacitor effectiveness.
2. Items not supplied in kit. See auto parts dealer.

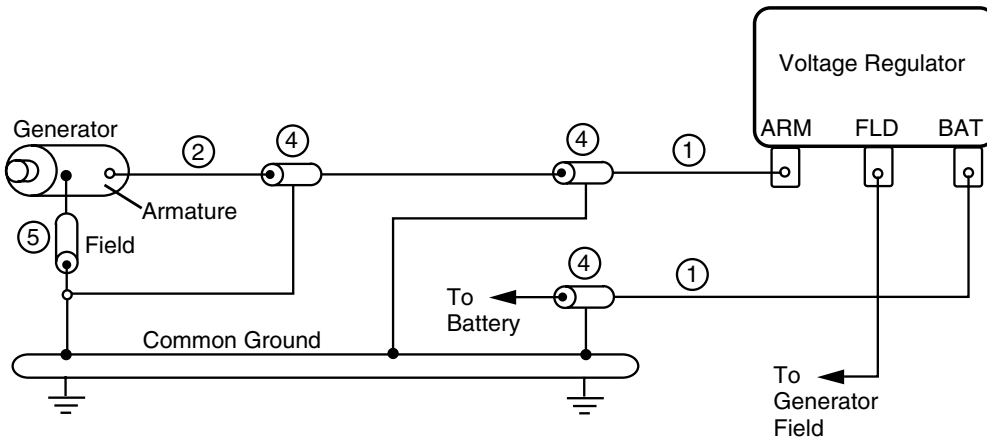

FL0830263-O

Reference Number	Quantity	Motorola Part Number	Description
1	3	0100839913	Lead & Lug Assembly
2	1	0180700A88	Lead & Lug Assembly
3	1	0882571B02	Capacitor, Coaxial (0.1µF, 100V)
4	3	0882571B01	Capacitor, Coaxial (0.5µF, 100V)
5	1	0180700A89	Generator Field Suppressor Assembly
6	1	3000502396	Ignition Coil Suppressor Cable
-	1	0180700A91	Hood Wipers (2) and Mounting Hardware Kit (not illustrated).

Figure 2-4 TLN6252_ Noise Reduction Kit for Generator-Equipped Vehicles

3.2 Sources of Noise

Some interference is due to geographic location. This interference does not need to be eliminated since it is possible for the vehicle to be moved away from the interfering noise source. Noise from power lines, fluorescent lights, and other vehicles (emitting high levels of radiated noise) are examples of noise which depends upon location. Make certain that you are not attempting to suppress noise in a vehicle while it is in a noisy location. If you suspect that your location is noisy, simply turn off everything in the vehicle except the radio and listen to the remaining ambient noise. If the noise level is objectionable, you may have to noise suppress the vehicle during a less noisy time of day or in a different, quieter location.

Check the installed radio for conducted and inducted noise by using an unmodulated signal generator to supply a clean RF signal through a coaxial cable directly to the antenna connector on the radio set. This should prevent radiated noise from entering the receiver and masking conducted and induced noise. Make certain that the signal generator is not microphonic and is placed away from the noise of the engine and exhaust.

Operate the controls for fans, blowers, power windows, headlamps, turn signals, windshield wipers, and other electrical accessories. Listen for the presence of noise in the received radio signal. This will allow the source of the interference to be determined. Some noise sources cannot be turned on and off at will. These sources will need to be attacked piecemeal on a trial and error basis: alternator whine, voltage regulators, electric fuel pump, and other possible sources. Remember that induced noise can result from radio wiring being too close to other vehicle wiring. This problem is most easily solved by proper cable routing at the time of installation.

Radiated noise must be attacked after conducted and induced noise has been satisfactorily suppressed. The vehicle ignition system is usually the primary source of this interference. Antenna placement can be critical in some installations. Remember that static discharge generates static or radiated noise and will probably be generated only when the vehicle is in motion.

Since radiated noise interference is most noticeable in weak signal areas, it is suggested that suppression be finalized while listening to a weak "on frequency" signal. (The squelch should be "open" so that even marginal signals can be heard.)

4.0 Noise Reduction Techniques

4.1 General

There are three basic ways to suppress noise. The first is the addition of resistance in circuits subject to ringing. This method is used for the ignition coil HV cable, spark plug wires, and spark plugs. The second is to filter noise from low voltage wiring using coaxial bypass capacitors. The third is to control static charge build-up using wipers for movable parts such as automobile hoods and trunk lids, or flexible bonding leads for fixed members. Static in wheels may also be controlled using collector rings. Applications of each of these techniques are discussed below.

The vehicle manufacturer's service manual also may provide noise suppression information which is valuable in any first attempt at noise suppression.

4.2 Ignition System Interference

4.2.1 Engine Maintenance and Tune-Up

The most important step in reducing ignition noise is insuring that the engine is in proper tune. Pay particular attention to the following points if the noise interference from the ignition system is severe:

1. Be sure the spark plugs distributor points, and condenser are in good condition.
2. Be sure ignition timing is properly adjusted.
3. Be sure the distributor cap and rotor are in good condition. They should be replaced at least every 30,000 miles.
4. Be sure that spark plug wires make good, solid contact at each end and are routed as far as possible from low voltage leads.
5. Many late-model automobiles are equipped with a shield over the distributor points. Check to see that this shield is properly positioned and securely attached.

4.2.2 Available Noise Reduction Kits

Motorola offers two noise reduction kits: Model TLN8845_ for alternator-equipped vehicles; Model TLN6252_ for generator-equipped vehicles. These kits are for suppression of noise in the primary and secondary of the ignition coil and for bleeding of static charges on the hood. The TLN6252_ also is used to suppress noise from the generator and voltage regulator. Figure 2-3 TLN8845_ Noise Reduction Kit for Alternator-Equipped Vehicles and Figure 2-4 TLN6252_ Noise Reduction Kit for Generator-Equipped Vehicles show the contents of the kits and their usage.

Motorola also offers wheel static collectors (Motorola Part No. 0100534254-regular type and 0100563173-small type). Use of these items are described in section "4.7 Wheel Static" on page 12.

Most auto parts dealers can supply 0.05 μF bypass capacitors (condensers), resistive ignition wires, and resistor spark plugs. The type of spark suppression used in noise reduction should always be in accordance with the recommendations of the vehicle manufacturer, that is, if spark plugs are to be replaced with built-in suppressor types, they should be in the proper heat ranges and thread sizes for the particular engine. In each ignition system, there is a maximum amount of resistance that may be connected between the distributor and a spark plug. If resistance-type ignition wire is used, the length of each wire must be limited so that its resistance does not exceed the allowable maximum.

4.2.3 Ignition Coil Interference

This type of interference is characterized by a popping sound which is most noticeable when the engine is running slowly. To suppress the noise, connect a 0.1 μF coaxial capacitor (Motorola Part No. 0882571B02) from the battery side of the ignition coil to vehicle ground (see Figure 2-5 Ignition Coil Noise Suppression). This keeps the distributor noise from being conducted through the battery lead into the electrical system of the vehicle. Note that some electronic ignition systems do not route the battery lead to the ignition coil; proper operation of the ignition system can be impaired if the "input" terminal is bypassed.

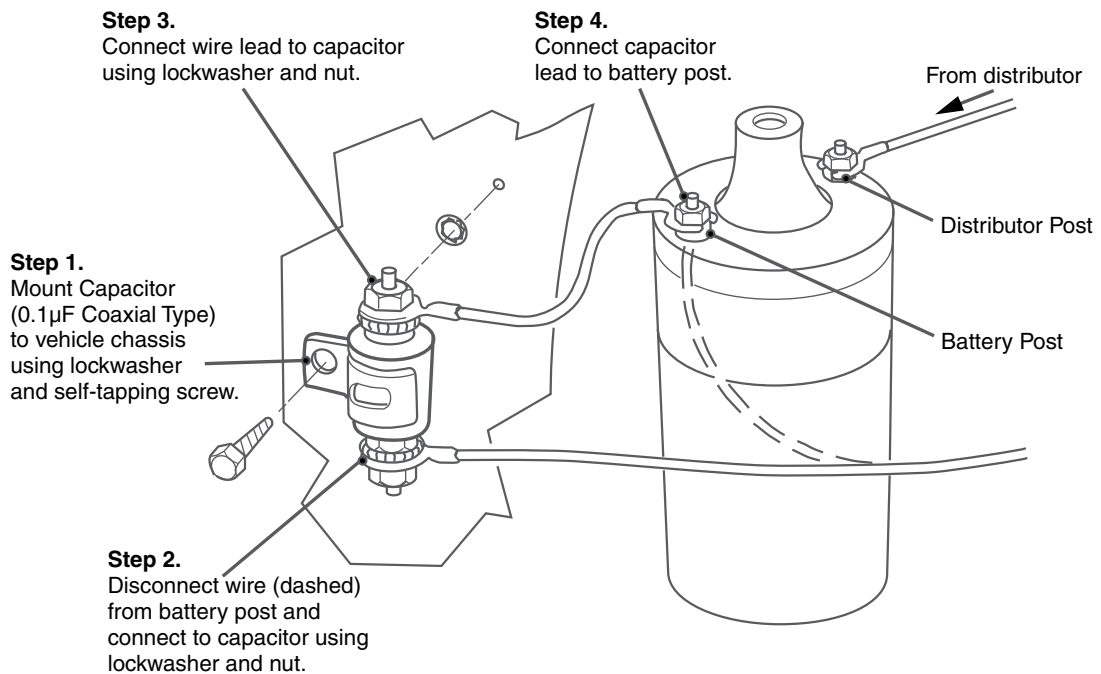

FL0830264-O

Figure 2-5 Ignition Coil Noise Suppression

4.2.4 Distributor Interference

This type of interference is characterized by popping sounds which are present at all engine speeds. It is caused by sparking between the rotor and the distributor cap inserts as the rotor turns. To suppress this noise, use resistance ignition wire to connect the ignition coil to the distributor cap.

4.2.5 Battery Connections

The radio set power cable can pick up noise generated in the vehicle. This can be minimized by connecting the power cable directly to the battery instead of the fuse block. The battery acts like a large capacitor (about one Farad for a 50 amp/hour battery), which bypasses induced noise. The battery ground lead should be securely bonded to the vehicle frame. Undesirable parallel ground currents can be minimized by using the vehicle frame as a common ground point. If ignition switch control of the radio is desired, the radio power leads may be connected to the battery through a relay which is controlled by the ignition switch.

4.3 Alternator/Generator Whine

This type of interference is characterized by a high-pitched whine which varies with engine speed. A 0.5 μ F coaxial capacitor (Motorola Part No. 0882571B01) can be used to bypass the whine. For generators, the capacitor is connected in the armature lead. Never use a capacitor in the field lead. Use the field suppressor assembly supplied in the TLN6252_ Noise Reduction Kit. For alternators, the capacitor is connected in the lead to the battery post (see Figure 2-6 Generator Whine Suppression and Figure 2-7 Alternator Whine Suppression).

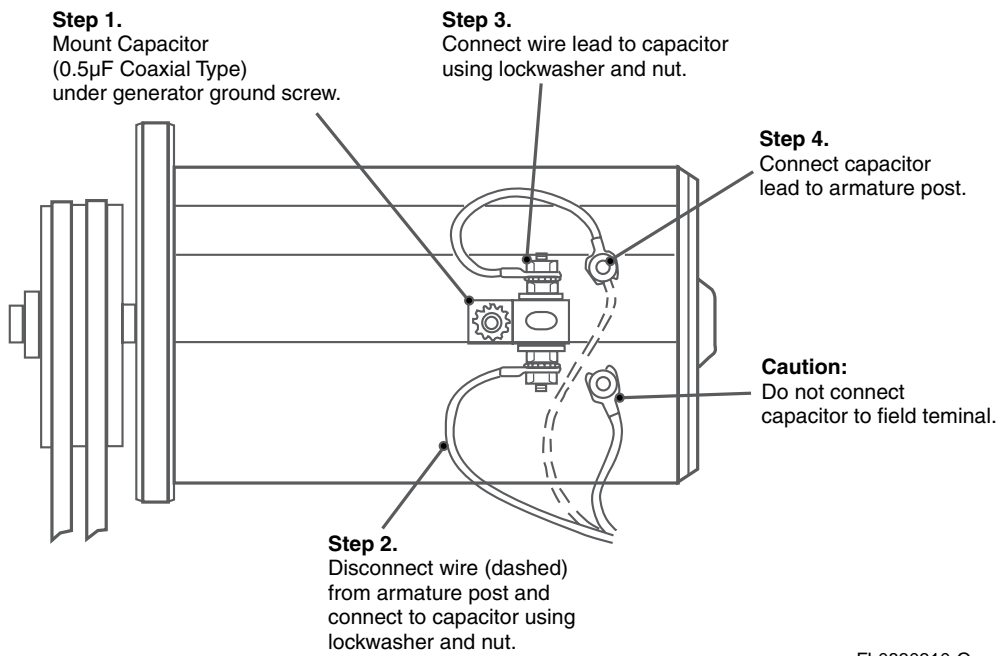

Figure 2-6 Generator Whine Suppression

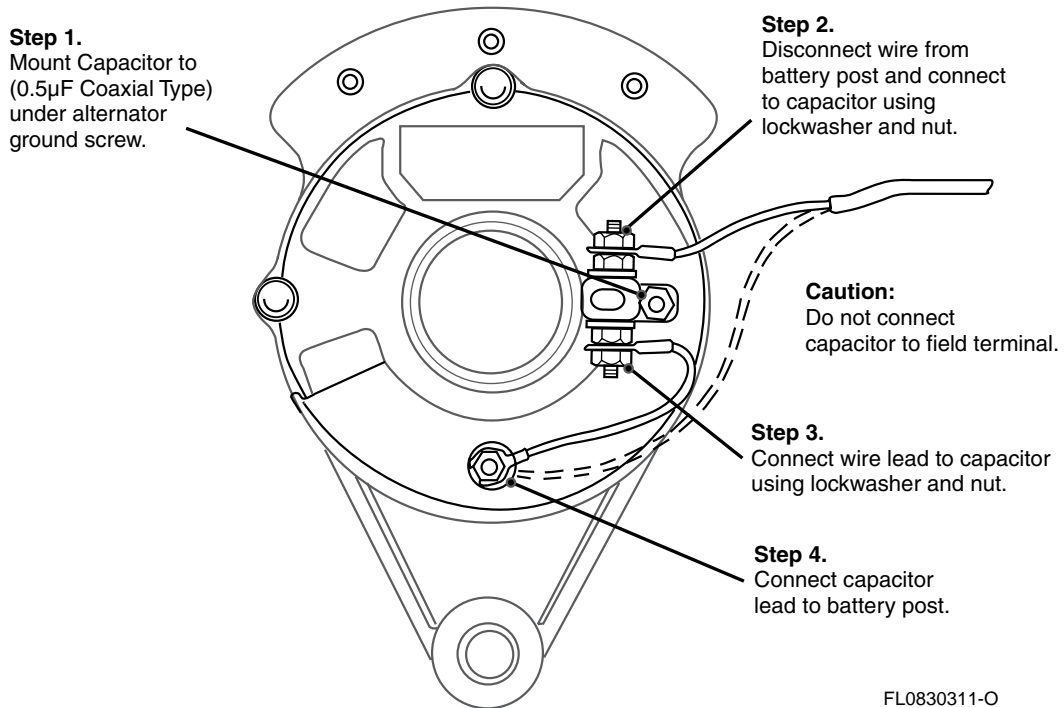

Figure 2-7 Alternator Whine Suppression

4.4 Voltage Regulator Noise

This type of interference is characterized by erratic popping noises which change only slightly with changes in engine speed. The noise is generated by arcing in the vibrating breaker contacts of the voltage regulator. It can be suppressed by connecting a 0.5 μF coaxial capacitor (Motorola Part No. 0882571B01) in the battery and armature leads of the voltage regulator (see Figure 2-8 Voltage Regulator Noise Suppression).



CAUTION: Disconnect the battery ground terminal before attempting to connect components to the voltage regulator.

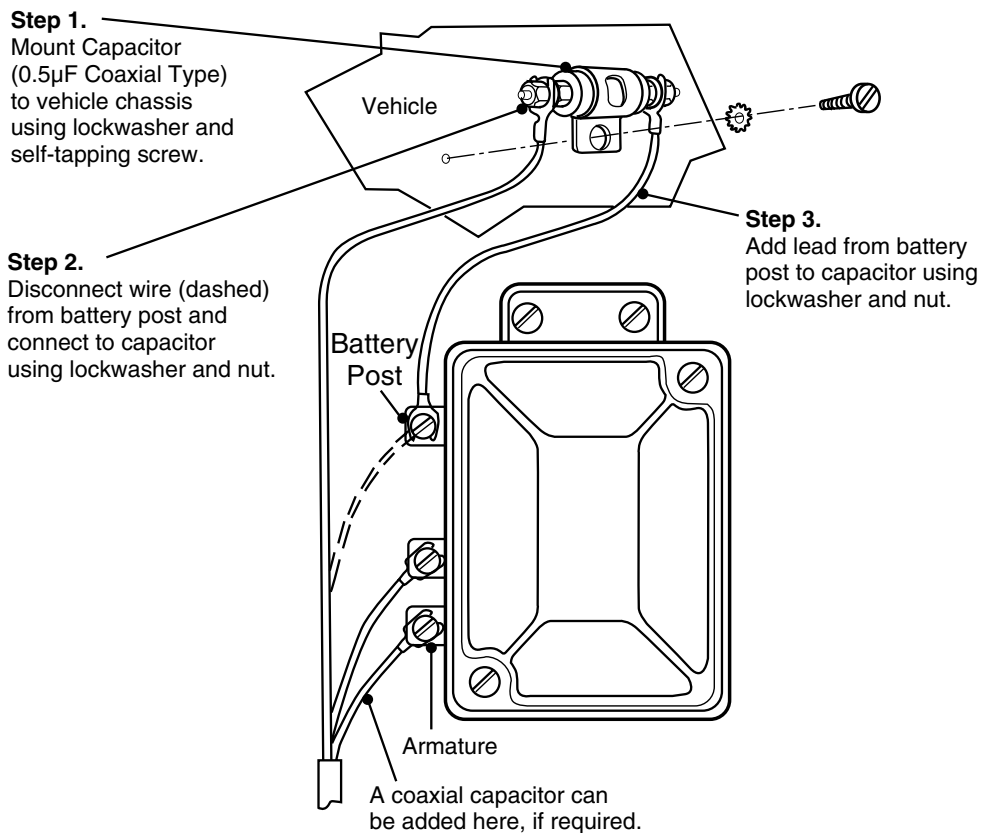

FL0830265-O

Figure 2-8 Voltage Regulator Noise Suppression

4.5 Hood and Trunk Lid Noise

This type of noise is characterized by irregular popping sounds. It is caused by friction in poorly bonded automobile hoods or trunk lids. This friction causes static electricity to build up until arcing occurs. This type of noise is suppressed using a Motorola Hood Wipers and Mounting Hardware Kit (part of TLN8845_ or TLN6252_ Noise Reduction Kits) which provides electrical bonding of the hood or trunk to the vehicle body while permitting them to be opened.

4.6 Other Electrical Noises

Other elements of the electrical system which can generate noise are listed below. These can be suppressed by connecting a 0.5 μF bypass capacitor between the noise source and ground.

1. Ammeter-to-battery lead
2. Gauges (oil, fuel, temperature)
3. Ignition Switch
4. Lamp bulbs (headlamps, tail lamps, dome lamps, etc.)
5. Accessory wiring (electrical fuel pump, electric windshield wipers, heater fan motor, window openers, etc.)

4.7 Wheel Static

Road friction can cause static build-up on the front wheels. Suppress noise from this source using wheel static collector rings (Motorola Part No. 0100534254 regular type - 0100653173 small type).

4.8 Ground Bonding

If a vehicle is not properly bonded to ground, static charges can increase. This increase can cause noise from electrical arcing. This type of noise is suppressed by bonding the part using one-inch wide ground straps (keep them as short as possible). Some common points where bonding may be helpful are listed below (see Figure 2-9 Ground Bonding).

- A. From engine block to the firewall.
- B. From engine block to vehicle frame at points where the engine is shock-mounted.
- C. From the battery ground terminal to the vehicle body.
- D. From top of front wheel "A" frames to chassis, particularly in cases where rubber-mounted members are used.

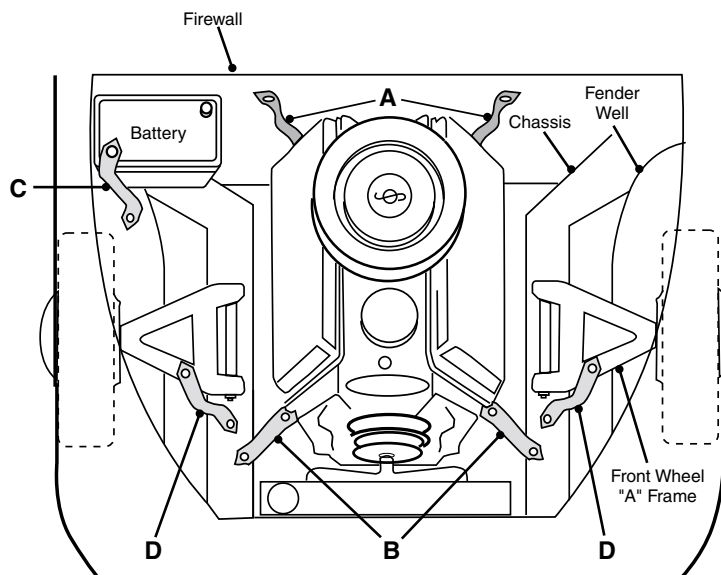

FL0830266-O

Figure 2-9 Ground Bonding